

Specifications

MODELS	ST™-20		ST™-25	
MEASUREMENTS	Metric	US	Metric	US
A Height - stowed	2.20 m	6 ft 6.75 in	2.20 m	6 ft 6.75 in
B Length - stowed	0.64 m	2 ft 1.25 in	0.64 m	2 ft 1.25 in
C Width - stowed	0.56 m	1 ft 10 in	0.56 m	1 ft 10 in
D Load height minimum	0.15 m	6 in	0.15 m	6 in
E Ground clearance - centre	0.05 m	2 in	0.05 m	2 in
Working height - forks up	6.46 m	21 ft 2.5 in	7.94 m	26 ft .5 in
- forks down	5.94 m	19 ft 6 in	7.42 m	24 ft 4 in
PRODUCTIVITY				
Load capacity - at 18 in load centre	363 kg	800 lbs	295 kg	650 lbs
Length - adjustable forks	0.70 m	27.5 in	0.70 m	27.5 in
Width - adjustable forks	0.29–0.76 m	11.5–30 in	0.29–0.76 m	11.5–30 in
Fork extensions detached each (l/w/d)	76 x 5 x 8 cm; 2 kg	30 x 2 x 3 in; 4.5 lbs	76 x 5 x 8 cm; 2 kg	30 x 2 x 3 in; 4.5 lbs
Fork extensions attached each (l/w/d)	64 x 5 x 8 cm; 2 kg	25 x 2 x 3 in; 4.5 lbs	64 x 5 x 8 cm; 2 kg	25 x 2 x 3 in; 4.5 lbs
Weight - adjustable forks	24 kg	52.5 lbs	24 kg	52.5 lbs
Outrigger footprint	1.87 x 2.02 m	73.5 x 79.5 in	1.87 x 2.02 m	73.5 x 79.5 in
Casters	standard casters		standard casters	
POWER				
Average cranks: standard winch	27.8 cranks/m	8.5 cranks/ft	27.8 cranks/m	8.5 cranks/ft
two speed winch, high	13.1 cranks/m	4 cranks/ft	13.1 cranks/m	4 cranks/ft
two speed winch, low	49.2 cranks/m	15 cranks/ft	49.2 cranks/m	15 cranks/ft
WEIGHT*				
	507 lbs	230 kg	252 kg	555 lbs

* Weight will vary depending on options and/or country standards.

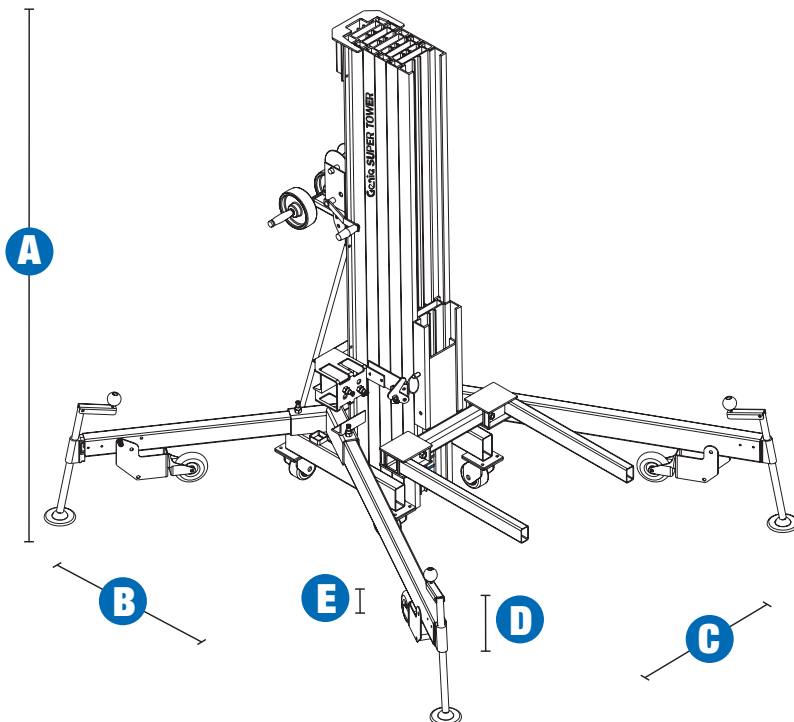

Features

STANDARD FEATURES

MEASUREMENTS

ST™-20

- 6.46 m (21 ft 2.5 in) maximum working height

- Up to 363 kg (800 lbs) load capacity

ST™-25

- 7.94 m (26 ft 0.5 in) maximum working height

- Up to 295 kg (650 lbs) load capacity

PRODUCTIVITY

- Standard base
- Standard casters
- Use as a single unit, or two or more can be used together to support trusses
- Flat black anodized finish is nearly invisible to audience
- Portable and compact design
- Lightweight, durable aluminium construction
- Single-door access
- Easy set-up with no tools required
- Durable steel forks
- Hand winch locks in place when handle is released
- Easy to transport—no bulky base
- Hold-down mechanism secures carriage during transport

POWER OPTIONS

- One-speed manual winch
- Reversible winch handle for easy storage

OPTIONS & ACCESSORIES

PRODUCTIVITY

- Load platform
- Fork extensions

POWER

- Two-speed manual winch



Genie Australia – Toll free number 1800 788 633

Brisbane (Head Office)
33 Kimberley Street
Darra QLD 4076

Sydney
74 Glendenning Road
Glendenning NSW 2761

Melbourne
374 Hammond Road
Dandenong VIC 3175

Perth
83 Bannister Road
Canning Vale WA 6155

Genie United States Distributed by:

18340 NE 76th Street
P.O. Box 97030
Redmond, Washington
98073-9730