

## LIGHT TOWER

# LIGHT TOWER AL8000 HT



The unique articulated hydraulic mast is ideal for the mining industry, as well as use on railroad, municipal and large construction sites.

### Features

Articulated hydraulic mast provides maximum flexibility and control for quick, effortless light positioning.

8.76 m (28 ft 9 in) vertical height, 6.10 m (20 ft) horizontal outreach and 359 degree powered rotation.

2.5 m (8 ft 2 in) stowed length provides for ease of transport for towing or transportation on a trailer or container.

Environmental spill containment to meet local regulations or for use in sensitive areas.

100 km/h towing speed for ease of transport.

100 km/h wind speed rating for maximum flexibility on site.

Auto start/stop timer with photo cell includes audible and visual start up warning system.

65 hours of run time before refuelling.

Individual plug-in ballasts installed in galvanized steel boxes. Can be replaced without disconnecting wiring terminals.

Control panel is inside, away from the elements. Houses main and branch circuit breakers and hourmeter.

Galvanized outriggers with pre-set position stops ensure quick and proper spacing.

Single point lifting eye and forklift pockets provide for easy loading and unloading.

# Light Tower

## AL8000 HT

### Specifications - Standard Unit

Lamps	Metal Halide 8 x 1,000 W
Generator	Brushless 60 Hz, 12 kW
Mast Rotation	359° powered rotation
Light Bar Tilt	180°
Individual Light Pivot	180° front-to-back, 360° side-to-side
Engine	12kW-16 hp Kubota Diesel
Fuel Capacity	221 L (60 gal)
Wheel Size	40 cm (16 in)
Axle Rating	1,905 kg (4,200 lbs)
Tongue weight travel position	159 kg (350 lbs)
Total weight no fuel	1,500 kg (3,300 lbs)
Photocell auto start	
Programmable electronic auto start/stop	
Lockable Battery Isolation Switch	
External emergency stop	
Engine protection system	
Mast Travel lock limit switch	

### Dimensions

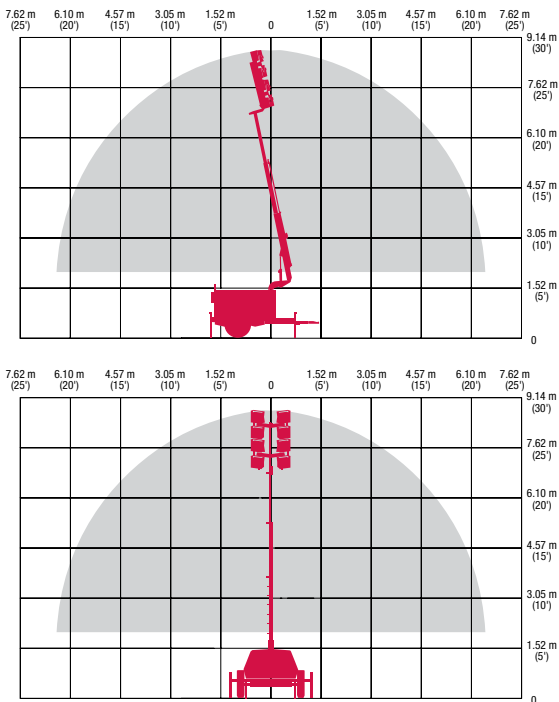

### Optional Equipment

Mine specification
Fire extinguisher

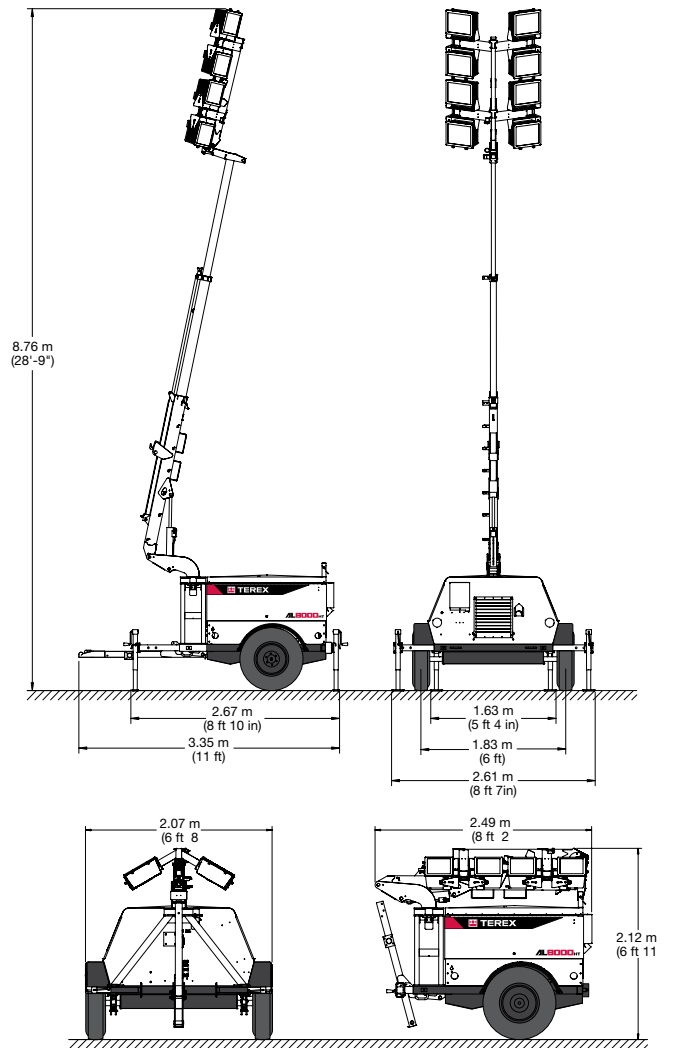

For more information, product demonstration, or details on purchase or lease plans, please contact your local Genie Sales Representative.

Effective Date: April 2012. Product specifications and prices are subject to change without notice or obligation. The photographs and/or drawings in this document are for illustrative purposes only. Refer to the appropriate Operators' Manual for instructions on the proper use of this equipment. Failure to follow the Operators Manual when using our equipment or to otherwise act irresponsibly may result in serious injury or death. The only warranty applicable to our equipment is the standard written warranty applicable to the particular product and sale and we make no other warranty, express or implied. Products and services listed may be trademarks, service marks, or trade names of Terex Corporation, Terex South Dakota, Inc., and/or their subsidiaries in the USA and other countries. All rights reserved. Terex is a registered trademark of Terex Corporation in the USA and many other countries. Genie is a registered trademark of Terex South Dakota, Inc. in the USA and many other countries. ©2009 Terex Corporation.